

# Summit Series II 1050W Industrial Battery Charger

Lester  
ELECTRICAL



The newest line of chargers from Lester Electrical, the Summit Series II charger family includes the most comprehensive feature set and best performance we have delivered in our fifty plus year history as a company. The chargers are ideal for use in any motive power application including golf cars, aerial work platforms, floor care machines, industrial vehicles, lift trucks and outdoor power equipment.



## AVAILABLE MODELS

48V / 22A

36V / 25A

24V / 25A



## BLUETOOTH®

Featuring Bluetooth wireless communication with apps for Apple® and Android™ phones and tablets. View charge cycle status, select the active battery profile, upload new profiles, change between on-board and off-board and download charge history records anytime using just a smart phone or tablet.



## CLOUD CONNECTIVITY

Push charge histories to the cloud to access data anywhere in the world. Enjoy expert technical support as our Lester Electrical staff can quickly see historical charging records. Add new charging profiles to your charger by pulling from the cloud and pushing to your charger.



## PERFORMANCE

Our Summit Series II provides industry-leading charging performance and intelligence. Our proprietary Progressive DV/DT™ charge algorithm ensures a precisely charged battery every time. The chargers are tested in extreme temperatures and operating conditions and built to last.



## EXPERTISE

Lester has been designing and manufacturing industrial battery chargers for more than fifty years. We are an employee owned company and every member of our team is invested in the quality we deliver our customers.



## EFFICIENCY

Our switch mode (high frequency) chargers have best-in-class efficiency and are compliant with the newest CEC and DOE standards. We operate a CEC approved laboratory in our Lincoln, NE manufacturing plant.



## FLEXIBILITY

Universal AC input and external DC and signal connections allow for easy customization and worldwide use. Our 1050W offers multi-voltage support allowing one charger to operate at 24V, 36V, or 48V.

# SPECIFICATIONS

AC INPUT	
Voltage range, rated	100-240 Vac
Voltage range, operating	85-265 Vac ( $< 108$ Vac: reduced power)
Frequency, rated	50-60 Hz
Frequency, operating	45-65 Hz
Phase	Single-phase
Current, maximum	$< 12$ A
Efficiency	$> 91\%$ peak, CEC test procedure, 115 Vac, AC and DC losses included
Protection	Current limit, surge, transient, under voltage, over voltage

DC OUTPUT			
Power	1050 W		
Voltage, nominal	24 Vdc	36 Vdc	48 Vdc
Voltage, maximum	36 Vdc	54 Vdc	72 Vdc
Current, maximum	25 A	25 A	22 A
Voltage, min start-up	10 Vdc		
Battery types	Lead-acid (Wet / AGM / Gel), lithium, custom		
Protection	Current limit, short circuit, reverse polarity, under voltage, over voltage, wrong battery voltage		

ENVIRONMENTAL	
Enclosure rating	IP66, NEMA 4
Operating temperature	$-25^{\circ}\text{C}$ to $60^{\circ}\text{C}$ ( $-13^{\circ}\text{F}$ to $140^{\circ}\text{F}$ )
Storage temperature	$-40^{\circ}\text{C}$ to $85^{\circ}\text{C}$ ( $-40^{\circ}\text{F}$ to $185^{\circ}\text{F}$ )

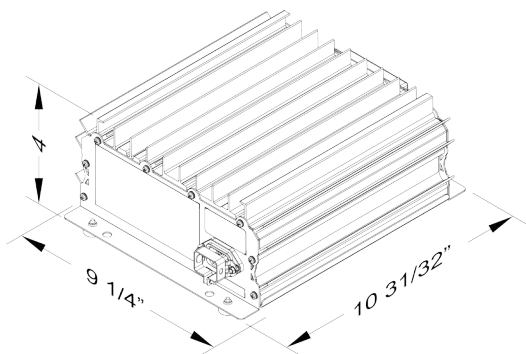

Specifications are subject to change without notice. Copyright Lester Electrical of Nebraska, Inc. All rights reserved.

The Bluetooth® word mark and logos are registered trademarks owned by Bluetooth SIG, Inc., and any use of such marks by Lester Electrical is under license. Other trademarks and trade names are those of their respective owners.

Apple is a trademark of Apple Inc., registered in the U.S. and other countries. App Store is a service mark of Apple Inc., registered in the U.S. and other countries.

Android is a trademark of Google Inc. Google Play and the Google Play logo are trademarks of Google Inc.

CANopen® is a registered trademark of CAN in Automation in Europe.

USER & VEHICLE INTERFACES	
Bluetooth Wireless	Apps for Apple and Android phones and tablets
LEDs	Charge Complete (green), Charge Status (yellow), AC Present (blue), Fault (red)
Lockout / interlock	Single wire
Remote LEDs	Charge Complete (green), Charge Status (yellow), output and LED assembly optional

MECHANICAL	
Dimensions (LxWxH), (removable feet not included)	10.969 x 9.250 x 4.000 in (279 x 235 x 102 mm)
Cooling	Natural convection (no fan)
AC input connector	IEC 60320 C16 inlet with cord clamp
DC output connector	External terminals with cover
Lockout connector	External terminal with cover
Mounting	Shelf, wall, bulkhead, threaded rod, hook
Handle	Carrying handle optional

SAFETY/REGULATORY	
Efficiency	CEC Appliance Efficiency Regulations, Title 20; DOE Code of Federal Regulations, 10 CFR Part 430
Safety / Emissions	UL recognized/listed; cUL/CSA certified; FCC Part 15; ICES-003; EN safety, emissions, immunity; CE Certified; ACMA RCM (C-Tick)



WEBSITE: [www.LesterElectrical.com](http://www.LesterElectrical.com)

PHONE: (402) 477-8988

E-MAIL: [Jilla@LesterElectrical.com](mailto:Jilla@LesterElectrical.com)

Lester Electrical  
625 West A Street, Lincoln, NE 68522, USA