



SUMMIT®

SERIES

**SWITCH MODE
INDUSTRIAL BATTERY CHARGER**

USER'S MANUAL

*Important Safety,
Installation,
Operation, and
Maintenance
Instructions*



www.LesterElectrical.com

CHARGER RATINGS LABEL

The ratings label is located on the back of the charger. The label provides the model (MODEL), part number (PART NO), serial number (SERIAL NO), AC input ratings (INPUT), and DC output ratings (OUTPUT, CELLS, and AH) of the charger. The amp-hour (AH) rating indicates the full range of battery capacities that are recommended for use with this charger. Different battery profiles may be required to optimize the charging of specific battery capacities within this range. The BATTERY field indicates the factory-configured battery profile.

An example charger ratings label is provided below.

				
SERIAL NO	101303167			
PART NO	27790G05K5B1W1			
OUTPUT	48VDC	13A		MODEL 27790
INPUT	100-230VAC	50-60Hz	1PH	<8A
BATTERY	WET(PDVDT)	24CELLS	140-225AH	

Please fill in the blank label that is provided below with the information from the ratings label on your charger for future reference.

				
SERIAL NO	_____			
PART NO	_____			
OUTPUT	____VDC	__A		MODEL _____
INPUT	_____	____Hz	__PH	__A
BATTERY	_____	__CELLS	_____AH	

Document any configuration or settings changes that are made by marking the ratings label on your charger or on an additional label or tag attached to your charger.

SAVE THIS MANUAL: Keep it in a location where it is available to anyone who may operate the charger.

TABLE OF CONTENTS

CHARGER RATINGS LABEL	2
TABLE OF CONTENTS	3
IMPORTANT SAFETY INSTRUCTIONS	4
1. INTRODUCTION	6
2. RECEIVING AND INSTALLING THE CHARGER.....	6
3. BATTERY TYPE	8
4. OFF-BOARD (SHELF) VERSUS ON-BOARD (BUILT-IN) CHARGERS.....	9
4.1 Off-Board Chargers	9
4.2 On-Board Chargers	9
5. AC INPUT.....	9
6 DC OUTPUT.....	10
7 VEHICLE LOCKOUT CONTROL (OPTIONAL).....	10
8 BATTERY TEMPERATURE SENSOR (OPTIONAL).....	11
9. PROPER CARE OF DEEP-CYCLE LEAD-ACID MOTIVE POWER BATTERIES	11
9.1 Personal Safety Precautions	12
10. CHARGER OPERATION	12
10.1 Off-Board Charger Operation	13
10.2 On-Board Charger Operation	14
10.3 Storage Mode Operation	14
11. LED INDICATORS	15
12. FAULTS	16
13. TROUBLESHOOTING	17
14. SPECIFICATIONS.....	18

IMPORTANT SAFETY INSTRUCTIONS

1. **SAVE THESE INSTRUCTIONS** – This manual contains important safety and operating instructions.
2. Before using battery charger, read all instructions and cautionary markings on battery charger, battery, and product using battery.



LOOK FOR THIS SYMBOL TO POINT OUT SAFETY PRECAUTIONS. IT MEANS: *BE ALERT—YOUR SAFETY IS INVOLVED.* IF YOU DO NOT FOLLOW THESE SAFETY INSTRUCTIONS, INJURY OR PROPERTY DAMAGE CAN OCCUR.

3. **⚠ DANGER:** TO REDUCE THE RISK OF FIRE OR ELECTRIC SHOCK, CAREFULLY READ AND FOLLOW THESE IMPORTANT SAFETY AND OPERATING INSTRUCTIONS BEFORE INSTALLING OR OPERATING THE CHARGER.
4. **⚠ INSTRUCTIONS IMPORTANTES CONCERNANT LA SECURITÉ.**
5. **⚠ WARNING:** TO REDUCE THE RISK OF FIRE, INSTALL THIS BATTERY CHARGER ON A SURFACE OF NON-COMBUSTIBLE MATERIAL SUCH AS BRICK, CONCRETE, OR METAL.
6. **⚠ DANGER:** RISK OF ELECTRIC SHOCK. DISCONNECT CHARGER FROM BATTERY AND AC POWER BEFORE SERVICING. TURNING OFF THE CHARGER DOES NOT REDUCE THIS RISK.
7. **⚠ DANGER:** RISK OF ELECTRIC SHOCK. DO NOT TOUCH UNINSULATED PORTION OF AC OR DC CONNECTORS OR UNINSULATED BATTERY TERMINAL.
8. **⚠ DANGER:** RISQUE DE CHOCS ÉLECTRIQUES. NE PAS TOUCHER LES PARTIES NON ISOLÉES DU CONNECTEUR DE SORTI OU LES BORNES NON ISOLÉES DE L'ACCUMULATEUR.
9. **⚠ CAUTION:** CHARGE ONLY BATTERIES OF THE SAME TYPE, VOLTAGE, CELL NUMBER, AND AMP-HOUR CAPACITIES AS SHOWN ON THE LABEL. OTHER TYPES OF BATTERIES MAY BURST CAUSING PERSONAL INJURY AND DAMAGE. BEFORE CHARGING ANY OTHER TYPE OF RECHARGEABLE BATTERY, CHANGE THE CHARGER SETTINGS AS RECOMMENDED BY THAT BATTERY MANUFACTURER.
10. **⚠ ATTENTION:** UTILISER POUR CHARGER UNIQUEMENT LES ACCUMULATEURS AU PLOMB À ELECTROLYTE LIQUIDE. D'AUTRES TYPES D'ACCUMULATEURS POURRAIENT ÉCLATER ET CAUSER DES.
11. **⚠ DANGER:** TO PREVENT ELECTRICAL SHOCK, DO NOT TOUCH EITHER AC OR DC UNINSULATED PARTS. MAKE SURE ALL ELECTRICAL CONNECTORS ARE IN GOOD WORKING CONDITION. DO NOT USE CONNECTORS THAT ARE CRACKED, CORRODED OR DO NOT MAKE ADEQUATE ELECTRICAL CONTACT. USE OF A DAMAGED OR DEFECTIVE CONNECTOR MAY RESULT IN A RISK OF OVERHEATING OR ELECTRIC SHOCK.
12. **⚠ WARNING:** HAZARD OF ELECTRIC SHOCK.
13. **⚠ WARNING:** LEAD-ACID BATTERIES GENERATE EXPLOSIVE GASES. TO PREVENT ARCING OR BURNING NEAR BATTERIES, DO NOT DISCONNECT DC CHARGING CORD FROM BATTERIES

WHEN THE CHARGER IS OPERATING. KEEP SPARKS, FLAME, AND SMOKING MATERIALS AWAY FROM BATTERIES.

14. **⚠ WARNING:** ALWAYS SHIELD EYES WHEN WORKING NEAR BATTERIES. DO NOT PUT WRENCHES OR OTHER METAL OBJECTS ACROSS BATTERY TERMINAL OR BATTERY TOP. ARCING OR EXPLOSION OF THE BATTERY CAN RESULT.
15. **⚠ WARNING:** BATTERIES PRODUCE HYDROGEN GAS, WHICH CAN EXPLODE IF IGNITED. NEVER SMOKE, USE AN OPEN FLAME, OR CREATE SPARKS NEAR THE BATTERY. VENTILATE THE AREA WHEN THE BATTERY IS CHARGING IN AN ENCLOSED PLACE.
16. **⚠ WARNING:** LEAD-ACID BATTERIES CONTAIN SULFURIC ACID, WHICH MAY CAUSE BURNS. DO NOT GET ACID IN EYES, ON SKIN, OR CLOTHING. IF CONTACT WITH THE EYES OCCURS, FLUSH IMMEDIATELY WITH CLEAN WATER FOR 15 MINUTES AND OBTAIN MEDICAL ATTENTION.
17. **⚠ WARNING:** ONLY A QUALIFIED SERVICE TECHNICIAN SHOULD PROGRAM OR SERVICE THIS EQUIPMENT.
18. **⚠ CAUTION:** DO NOT OPERATE THE CHARGER IF IT HAS RECEIVED A SHARP BLOW, BEEN DROPPED, OR OTHERWISE DAMAGED. HAVE A QUALIFIED SERVICE TECHNICIAN EXAMINE AND REPAIR AS NEEDED.
19. **⚠ WARNING:** DO NOT DISASSEMBLE THE CHARGER. HAVE THE CHARGER EXAMINED BY A QUALIFIED SERVICE TECHNICIAN. INCORRECT RE-ASSEMBLY OF THE CHARGER MAY RESULT IN AN EXPLOSION, ELECTRIC SHOCK, OR FIRE.
20. **⚠ CAUTION:** MAKE SURE THE BATTERY SYSTEM HAS THE PROPERLY RATED VOLTAGE, AMP-HOURS, AND TYPE (“WET”, “AGM”, “GEL”, ETC.) FOR THIS CHARGING SYSTEM.

SAVE THESE INSTRUCTIONS

1. INTRODUCTION

This switch mode (high frequency) industrial battery charger features advanced charge and termination algorithms designed to optimize both daily battery capacity and overall battery life. The charger is convection cooled with no moving parts, sealed, and designed to provide maximum reliability. The universal AC input enables the charger to be used with a wide range of AC voltages and frequencies, and the charger includes high efficiency and power factor.

The charger was factory-configured with a battery profile intended for use with batteries of the same type, voltage, and number of cells as is listed on the ratings label (see the Charger Ratings Label section for additional details). The charger was also factory-configured for on-board or off-board use. Contact your dealer if you require a different configuration.

2. RECEIVING AND INSTALLING THE CHARGER

⚠ WARNING: DO NOT INSTALL THE CHARGER ON OR NEAR FLAMMABLE MATERIALS. POSITION THE CHARGER ON A FOUNDATION OF STONE, BRICK, CONCRETE OR GROUNDED METAL.

⚠ WARNING: CHARGERS CAN IGNITE FLAMMABLE MATERIALS AND VAPORS. DO NOT USE NEAR FUELS, GRAIN DUST, SOLVENTS, THINNERS, OR OTHER FLAMMABLES.

⚠ WARNING: REPLACE WORN, DAMAGED, OR CUT ELECTRICAL CORDS AND PLUGS IMMEDIATELY.

Unpack the charger and examine it for shipping damage. In the event that shipping damage is found, report it as a claim with the freight company.

Do not operate the charger with a damaged AC or DC cable or connector. Do not operate the charger if it has received a sharp blow, was dropped, or was otherwise damaged in any way. Contact your dealer.

Proper installation is important to achieve optimum performance and life from the charger and batteries. Allow as much free air space around the charger as possible. Please refer to the Specifications section for specific storage and operating environmental specifications.

The charger was factory-configured for mounting on-board a battery-powered vehicle/machine or off-board use in a shelf or portable application. Contact your dealer if you desire to use the charger in a non-factory-configured manner.

The most favorable orientations of the charger are shown in Figure 2-1.

For on-board use, the most favorable way to mount the charger is with the charger base bolted to a metal plate (0.1 inch minimum). This provides both a strong structural mounting and good thermal conductive cooling (examples are shown in Figure 2-1, Views A and B). A poor thermal conductive mounting material such as plastic or wood would be less favorable for cooling.

The charger dimensions and mounting slot locations are shown in Figure 2-2. For off-board use, optional handles are available for ease in carrying.

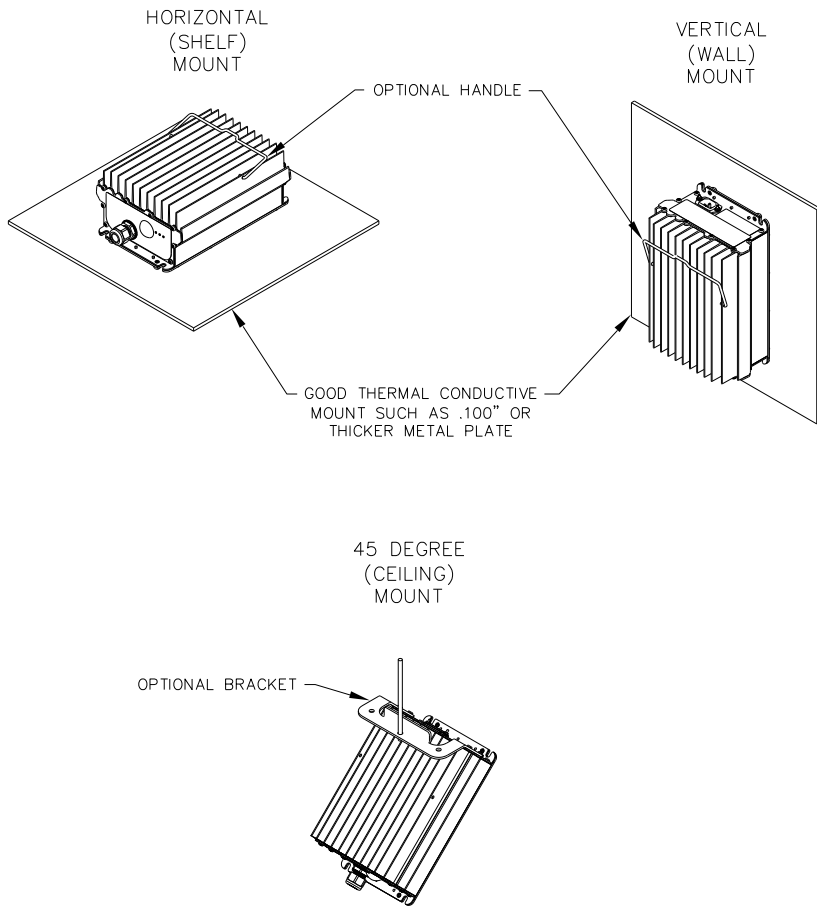

Figure 2-1: Charger Mounting Recommendations

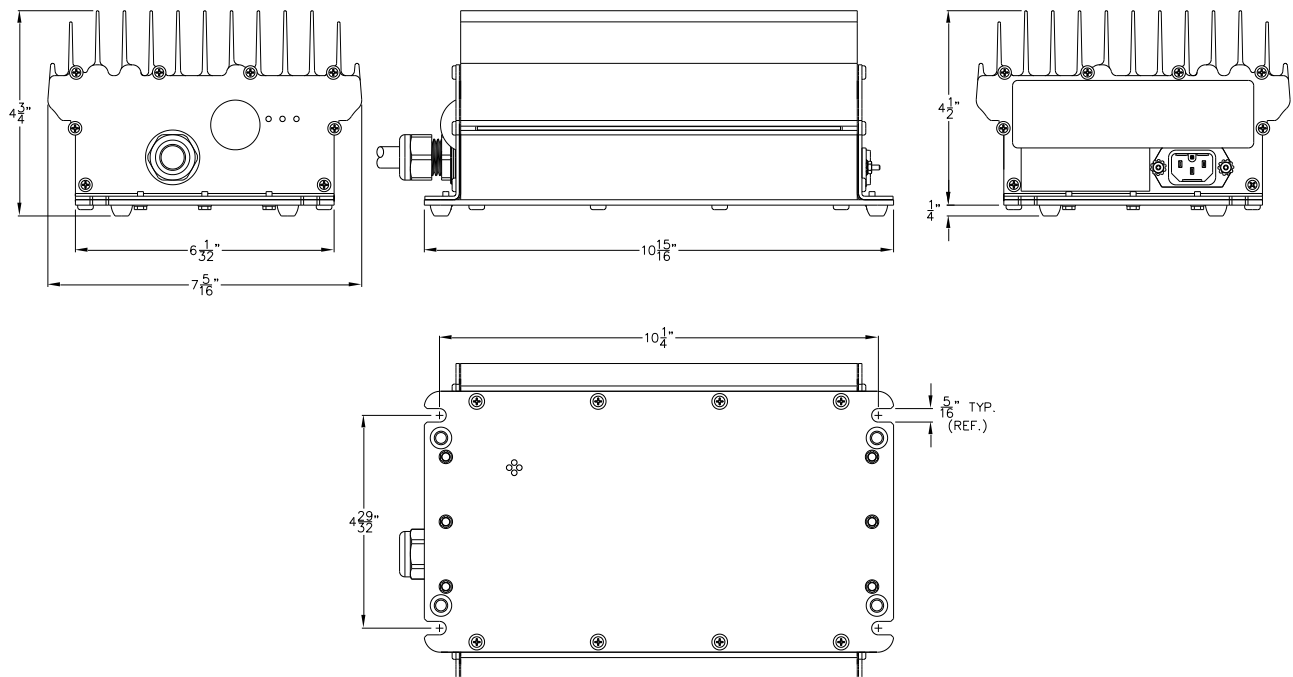

Figure 2-2: Charger Dimensions and Mounting Slot Locations (Case #1)

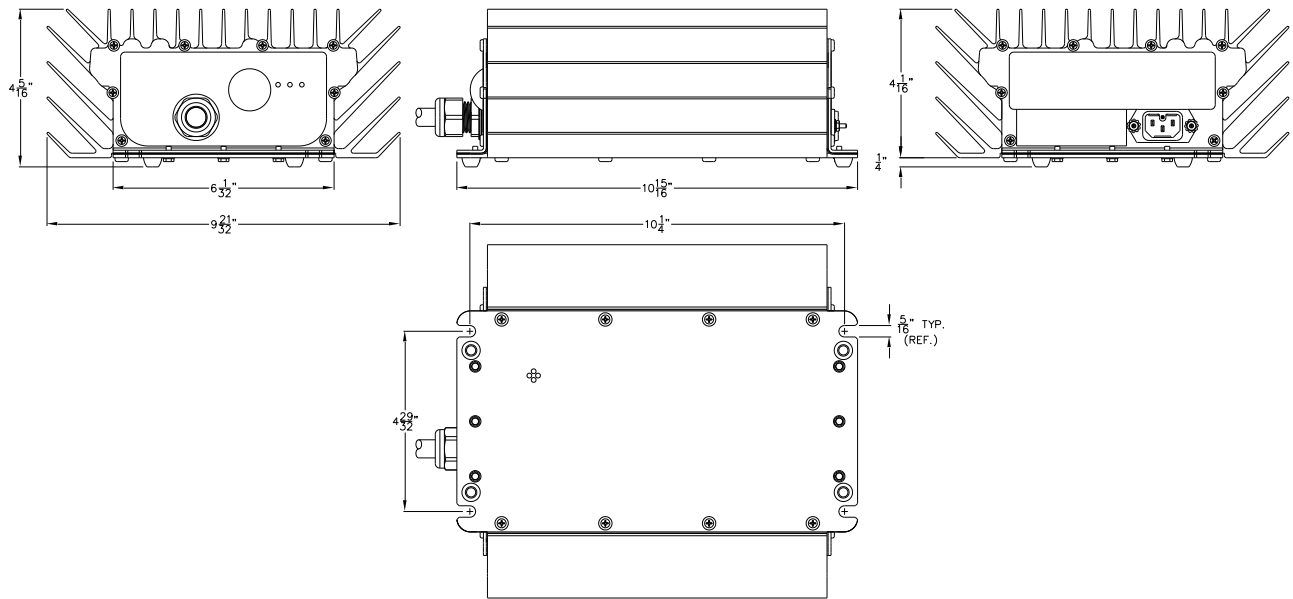

Figure 2-3: Charger Dimensions and Mounting Slot Locations (Case #2)

3. BATTERY TYPE

This charger was factory-configured to charge the type of battery indicated in the BATTERY field on the charger ratings label (for example, “Wet”). The 13th and 14th characters in the charger part number, available in the PART NO field on the charger ratings label, provide the battery profile code for the primary battery profile. For example, charger part number 27790G05K5B1W1 has a primary battery profile code of “W1” and charger part number 27790G05K5B1A1 has a primary battery profile code of “A1”. Figure 3-1 lists standard battery profile codes and their corresponding battery profiles. If the battery profile code for your charger is not listed in Figure 3-1, please contact your dealer for information. To change the active battery profile for this charger, please contact your dealer. If the active battery profile is changed, mark the charger ratings label or add an additional label or tag.

CAUTION: THIS CHARGER IS FOR USE ONLY WITH BATTERY SYSTEMS OF THE SAME TYPE AS THE ACTIVE BATTERY PROFILE. BATTERIES IMPROPERLY MATCHED WITH THE CHARGER MAY BURST CAUSING PERSONAL INJURY AND DAMAGE TO THE BATTERIES OR CHARGER.

Model	Rating	Part Number Battery Profile Code	Battery Profile
27790/27800	48V/13A	W1	Wet, standard, 4.5A finish
		W2	Wet, temp comp, 4.5A finish
		W4	Wet, standard, 6A finish
		A1	AGM, standard
		G1	Gel, standard
28110/28120	36V/14.5A	W1	Wet, standard, 6A finish
		A1	AGM, standard
		G1	Gel, standard
27940/27950	24V/25A	W1	Wet, standard, 7A finish
		W4	Wet, standard, 9A finish
		W6	Wet, standard, 11A finish
		A1	AGM, standard
		G1	Gel, standard

Figure 3-1: Standard Battery Profile Codes and Their Corresponding Battery Profiles

Model	Rating	Part Number Battery Profile Code	Battery Profile
28230	36V/21A	W1	Wet, standard, 7A finish
		W4	Wet, standard, 9A finish
		W6	Wet, standard, 11A finish
		A1	AGM, standard
		G1	Gel, standard
28000	48V/19.5A	W1	Wet, standard, 6A finish
		W4	Wet, standard, 8A finish
		W6	Wet, standard, 11A finish
		A1	AGM, standard
		G1	Gel, standard

Figure 3-1: Standard Battery Profile Codes and Their Corresponding Battery Profiles (Continued)

Battery manufacturers frequently use the same battery cases for different battery types. Wet/flooded batteries have removable cell caps. Water electrolyzed by discharging and charging the battery is replaced through these openings. Sealed batteries are generally distinguished by non-removable cell caps. The physical appearance of the battery case is frequently the same as a wet battery, though the cell caps are generally not removable. Refer to the battery manufacturer's information panel on the battery case to determine the type battery you have. If the information panel is missing or not legible, do not use the battery.

4. OFF-BOARD (SHELF) VERSUS ON-BOARD (BUILT-IN) CHARGERS

4.1 Off-Board Chargers

Off-board chargers are designed to be used in shelf or portable applications. If the AC input plug is connected to AC power, a new charge cycle automatically starts when the DC output is connected to a battery pack of the proper voltage. Disconnecting and reconnecting AC power while the DC output remains connected to a battery pack WILL NOT automatically start a new charge cycle. Disconnecting the DC output from the battery pack IS REQUIRED to automatically start a new charge cycle.

4.2 On-Board Chargers

On-board chargers are designed to be mounted on electric vehicles/equipment. If the DC output is connected to a battery pack of the proper voltage, a charge cycle automatically starts when the AC input plug is connected to AC power (unless a safety period of time has not passed since the successful completion of the previous charge cycle). Disconnecting the DC output from the battery pack is NOT REQUIRED to automatically start a new charge cycle.

5. AC INPUT

The charger has an AC input rating of 100-230 volts, 50-60 hertz, single-phase. The charger has an AC operating range of 90-264 volts, 45-65 hertz. Below 100 volts, the charger may reduce output power.

The charger is equipped with an IEC inlet for the AC input power. This allows the AC power cord to be selected with a proper plug to be compatible with the local wall outlets. An optional AC cord clamp is available to retain the AC power cord.

The charger must be grounded to reduce the risk of electric shock and is equipped with an IEC inlet having an equipment-grounding conductor and a grounding socket. The installed AC power cord must be plugged into an outlet that is properly installed and grounded in accordance with all applicable electrical codes and ordinances.

If this charger includes the UL Listed symbol on its ratings label, it is provided with a cord set for connection to outlets operating at nominal 120 volts (or 240 volts as appropriate). If the input plug does not fit the power outlet, contact Lester Electrical for the proper cord set terminating in an attachment plug of the proper configuration for the power outlet.

⚠ CAUTION: TO REDUCE THE RISK OF ELECTRIC SHOCK OR FIRE, DISCONNECT AC POWER FROM THE CHARGER BEFORE INSTALLING OR REMOVING UNIT.

⚠ DANGER: NEVER ALTER THE AC POWER CORD OR PLUG PROVIDED. IF IT WILL NOT FIT AN OUTLET, OBTAIN THE CORRECT CHARGER IEC AC CORDSET FOR THE OUTLET, OR HAVE A PROPER OUTLET INSTALLED BY A QUALIFIED ELECTRICIAN. IMPROPER CONNECTION CAN RESULT IN A RISK OF ELECTRIC SHOCK.

If an extension cord is necessary, it must be a 3-conductor, No. 12 AWG minimum, heavy-duty cord with ground. It must also be in good electrical condition and as short as possible, 50 ft (15m) maximum. Make sure that the pins on the plug of the extension cord are the same number, size, and shape as the AC power cord plug on the charger. The use of an improper extension cord could result in a risk of fire or electrical shock.

Locate all cords so that they will not be stepped on, tripped over, or otherwise subjected to damage, stress, or accidentally disconnected.

⚠ CAUTION: VERIFY THAT THE AC POWER CORD IS FULLY ENGAGED IN THE IEC INLET AND CANNOT BE PULLED LOOSE BEFORE USING THE CHARGER.

⚠ DANGER: RISK OF ELECTRIC SHOCK! CONNECT THE AC SUPPLY CORD DIRECTLY TO A GROUNDED, 3-WIRE OUTLET. DO NOT TOUCH UNINSULATED PORTION OF DC OUTPUT TERMINALS OR BATTERY TERMINALS. REPLACE DEFECTIVE CORDS, WIRES, OR CONNECTORS IMMEDIATELY.

6 DC OUTPUT

⚠ WARNING: LEAD-ACID BATTERIES GENERATE EXPLOSIVE GAS. CHARGE ONLY IN WELL VENTILATED AREAS. TO PREVENT ARCING OR BURNING NEAR BATTERIES, DO NOT DISCONNECT THE DC CHARGING CONNECTOR(S) FROM THE BATTERIES WHEN THE CHARGER IS OPERATING. IF THE CHARGE CYCLE MUST BE INTERRUPTED, UNPLUG THE AC POWER CORD BEFORE DISCONNECTING THE DC OUTPUT CONNECTOR(S) FROM THE BATTERIES. KEEP SPARKS, FLAME, AND SMOKING MATERIALS AWAY FROM BATTERIES. TO REDUCE THE RISK OF FIRE, DO NOT USE THE CHARGER NEAR FLAMMABLE MATERIALS OR VAPORS.

Only charge batteries of the same type, voltage, number of cells, and amp-hour capacities listed on the charger ratings label.

The DC output cordset includes a commonly-used connector/plug. The polarity of the charger DC connector/plug must be the same as the battery connector. The BLACK DC cable must be connected to the battery negative (-), and the WHITE or RED DC cable must be connected to the battery positive (+). The charger will not operate if the polarity is reversed.

7 VEHICLE LOCKOUT CONTROL (OPTIONAL)

The charger may be configured with an optional lockout/interlock control signal to prevent vehicle/equipment operation while the charger is in use. If the charger was factory-configured for on-board use, the lockout control signal will be active while AC power is applied to the charger. If the charger was factory-configured for off-board use, the lockout control signal will be active while a valid battery is connected to the charger.

The lockout control wire will be pulled down to battery negative (-) when active. Two (2) lockout control options exist. If you are uncertain of which one your charger includes, please contact your dealer.

Option #1

The lockout control wire is intended to be connected to the motor speed controller (MSC) lockout/interlock input. An internal pull-up resistor to battery positive (+) is included in order to pull the MSC lockout input high when the charger lockout control signal is not active.

Option #2

An external DC relay coil, with a minimum 2 kΩ resistance, can be connected in series from battery positive (+) to the lockout control wire. When the lockout control signal is active, it will energize the relay. The relay contacts can be used to lockout the vehicle using the key switch circuit, etc.

Alternatively, the lockout control wire can be connected to the motor speed controller (MSC) lockout/interlock input. A 10 kΩ, 1 Watt pull-up resistor to battery positive (+) should also be connected to the MSC lockout input in order to pull this input high when the charger lockout control signal is not active.

8 BATTERY TEMPERATURE SENSOR (OPTIONAL)

 WARNING: IT IS IMPORTANT TO MOUNT THE TEMPERATURE SENSOR ON THE BATTERIES FOR PROPER TEMPERATURE COMPENSATION.

The temperature sensor (if present) should be attached to a battery post near the center of the battery pack. If the threaded stud is long enough above the battery jumper nut, attach the probe with another nut. Torque this nut to proper specifications. If the stud is too short, the nut holding the jumper wire will need to be removed. Open or remove the load and charging circuits to the batteries. Remove the nut and add the sensor, then torque the nut to the proper specifications. Then close or connect the load and charging circuits back to the batteries.

Securely fasten the temperature sensor cable to protect the sensor from being torn from the battery. Secure the sensor cable to a fixed object to ensure the probe will not be pulled loose. Use a cable tie mount on the battery or on the adjacent battery, if necessary.

9. PROPER CARE OF DEEP-CYCLE LEAD-ACID MOTIVE POWER BATTERIES

Motive power battery packs are subjected to severe deep-cycle duty on a daily basis. Although these batteries are designed to withstand such duty, the following precautions must be observed to obtain good performance and maximum cycle life.

 CAUTION: ALWAYS WEAR PROTECTIVE EYE SHIELDS AND CLOTHING WHEN WORKING WITH BATTERIES. BATTERIES CONTAIN ACIDS WHICH CAN CAUSE BODILY HARM. DO NOT PUT WRENCHES OR OTHER METAL OBJECTS ACROSS THE BATTERY TERMINAL OR BATTERY TOP. ARCING OR EXPLOSION OF THE BATTERY CAN RESULT.

1. When installing new batteries, be sure the polarity of each battery and the overall battery pack is correct. Otherwise, battery and/or charger damage can result.
2. New batteries should be given a full charge before their first use because it is difficult to know how long the batteries have been stored.
3. New batteries and older batteries that have been in storage are not capable of their rated output until they have been discharged and charged a number of times. Consult the manufacturer of your batteries for more information.
4. **DO NOT EXCESSIVELY DISCHARGE THE BATTERIES.** Excessive discharge can cause polarity reversal of individual cells resulting in complete failure shortly thereafter.
5. Maintain the proper electrolyte level of wet (flooded) batteries by adding water when necessary. Distilled or deionized water is best for battery life. Never allow the electrolyte level to fall below the top of the battery plates. Electrolyte levels lower during discharge and rise during charge. Therefore, to prevent the overflow of electrolyte when charging, it is mandatory that water be added to cells **AFTER** they have been fully charged – do not overfill. Old batteries require more frequent additions of water than new batteries.
6. Hard crystalline sulfates form when batteries in storage are not maintained in a charged active state. Internal self discharge can bring about the start of this condition in as little as three days in warm temperatures. Batteries not maintained and allowed to sit in storage will self discharge, sulfate and lose capacity. Repeated charging without using the batteries between charges can recover some of the lost power, range, and life, but some permanent loss should be expected.
7. Cold batteries require more time to fully charge. When the temperature falls below 65°F, the batteries should be placed on charge as soon after use as possible.

-
8. The tops of batteries and battery hold downs must be kept clean and dry at all times to prevent excessive self discharge and the flow of current between the battery posts and frame. Electrolyte spilled on batteries never dries or evaporates.
 9. All connections to batteries must be maintained clean and tight. Due to heating and discharge rates, bolted connections loosen over time. Re-tighten the connections twice yearly to the torques specified by the battery manufacturers.
 10. Follow all operating instructions, cautions, and warnings as specified in this manual, on the charger, in the battery manuals, and in the vehicle manuals.

9.1 Personal Safety Precautions

1. Have someone within the range of your voice and close enough to quickly come to your aid when you work near a lead-acid battery.
2. Ensure that ample fresh water and soap are nearby in case battery acid contacts your skin, clothing, or eyes.
3. Wear complete eye and clothing protection. Avoid touching your eyes while working near a battery.
4. If battery acid contacts your skin or clothing, wash immediately with soap and water. If acid enters your eye, immediately flush your eye with running cold water for at least 10 minutes, and get medical attention immediately.
5. NEVER smoke or allow a spark or flame to be in the vicinity of a battery.
6. Be extra cautious to reduce the risk of dropping a metal tool onto a battery. It could spark or short circuit the battery or other electrical components that could cause an explosion.
7. Remove personal metal items such as rings, bracelets, necklaces, and watches when working with a battery. A battery can produce a short-circuit current that is high enough to cause a severe burn.
8. NEVER charge a frozen battery.

10. CHARGER OPERATION

 **WARNING: TO REDUCE THE RISK OF AN ELECTRIC SHOCK, CONNECT ONLY TO A SINGLE-PHASE, PROPERLY GROUNDED (3-WIRE) OUTLET. REFER TO GROUNDING INSTRUCTIONS.**

 **CAUTION: MAKE SURE THE BATTERY IS A RECHARGEABLE DEEP-CYCLE BATTERY WITH THE PROPER RATED VOLTAGE FOR THIS CHARGER.**

 **DANGER: TO PREVENT ELECTRICAL SHOCK, DO NOT TOUCH UNINSULATED PARTS OF THE CHARGER DC OUTPUT CONNECTOR, BATTERY CONNECTOR, OR BATTERY TERMINALS. MAKE SURE ALL ELECTRICAL CONNECTORS ARE IN GOOD WORKING CONDITION. DO NOT USE CONNECTORS THAT ARE CRACKED, CORRODED, OR DO NOT MAKE ADEQUATE ELECTRICAL CONTACT. USE OF A DAMAGED OR DEFECTIVE CONNECTOR MAY RESULT IN A RISK OF OVERHEATING OR ELECTRIC SHOCK.**

 **WARNING: CHARGER IS NOT TO BE USED WHILE THE BATTERY POWERED EQUIPMENT IS OPERATING.**

 **ATTENTION: NE PAS UTILISER LE CHARGER PENDANT QUE L'EQUIPMENT EST EN MARCHE.**

 **WARNING: LEAD-ACID BATTERIES GENERATE GASES WHICH CAN BE EXPLOSIVE. TO PREVENT ARCING OR BURNING NEAR BATTERIES, DO NOT DISCONNECT THE CHARGER DC OUTPUT FROM THE BATTERIES WHEN THE CHARGER IS OPERATING. KEEP SPARKS, FLAME, AND SMOKING MATERIALS AWAY FROM BATTERIES.**

⚠ WARNING: ALWAYS SHIELD EYES WHEN WORKING NEAR BATTERIES. DO NOT PUT WRENCHES OR OTHER METAL OBJECTS ACROSS BATTERY TERMINALS OR THE BATTERY TOP. ARCING OR EXPLOSION OF THE BATTERY CAN RESULT!

⚠ WARNING: DO NOT DISCONNECT THE CHARGER DC OUTPUT CONNECTOR FROM THE BATTERY CONNECTOR WHILE A CHARGE CYCLE IS IN PROGRESS. THE RESULTING ARCING AND BURNING OF THE CONNECTORS COULD CAUSE THE BATTERIES TO EXPLODE.

⚠ CAUTION: TO AVOID DAMAGE TO THE CHARGER DC CABLE AND CONNECTOR AND BATTERY CONNECTOR, DISCONNECT BY GRASPING THE CHARGER CONNECTOR HANDLE OR BODY AND PULLING IT STRAIGHT OUT OF THE BATTERY CONNECTOR. DO NOT PULL ON THE CHARGER CABLE. DO NOT TWIST, ROCK, OR PULL THE CONNECTOR SIDEWAYS.

The instructions printed on the charger are for daily reference.

10.1 Off-Board Charger Operation

If the charger was factory-configured for off-board use, follow these operating instructions:

1. With the charger DC output connector/plug disconnected from the battery connector/receptacle, connect the charger AC power cord to an appropriate AC outlet (if not already connected).
2. Connect the charger DC output connector/plug to the battery connector/receptacle. The charger will start automatically, which is indicated by the Charge Status (yellow) LED beginning to blink slowly.
3. If the charger must be disconnected from the battery while a charge cycle is in progress, first disconnect the AC power cord from the AC outlet. Do not disconnect the charger DC output connector/plug from the battery while a charge cycle is in progress.
4. The charge cycle 80% point is indicated by the Charge Status (yellow) LED beginning to blink quickly.
5. The Finish charge cycle phase is indicated by the solid illumination of the Charge Status (yellow) LED. Not all charge profiles include a Finish phase.
6. An extended Balance/Equalize charge cycle phase is indicated by the Charge Complete (green) LED beginning to blink quickly. Not all charge profiles include a Balance/Equalize phase.
7. The charger automatically terminates the charge cycle when a battery reaches full charge, which is indicated by [1] the solid illumination of the Charge Complete (green) LED or [2] the Charge Complete (green) LED beginning to blink slowly indicating a post-charge phase. The required charge time is affected by numerous factors, including battery amp-hour capacity, depth of discharge, battery temperature, and battery age/usage.
8. Before operating the machine/equipment, disconnect the charger DC output connector/plug from the battery connector/receptacle by firmly grasping both connectors and pulling them straight apart.

10.2 On-Board Charger Operation

If the charger was factory-configured for on-board use, follow these operating instructions:

1. Ensure that the vehicle/equipment that the charger is mounted on is turned off.
2. With the charger AC power cord disconnected from the AC outlet, connect the charger DC output connector/plug to the battery connector/receptacle (most likely already connected or hard wired).
3. Connect the charger AC power cord to an appropriate AC outlet. The charger will start automatically, which is indicated by the Charge Status (yellow) LED beginning to blink slowly.
4. If the charger must be disconnected from the battery while a charge cycle is in progress, disconnect the AC power cord from the AC outlet. Do not disconnect the charger DC output connector/plug from the battery while a charge cycle is in progress.
5. The charge cycle 80% point is indicated by the Charge Status (yellow) LED beginning to blink quickly.
6. The Finish charge cycle phase is indicated by the solid illumination of the Charge Status (yellow) LED. Not all charge profiles include a Finish phase.
7. An extended Balance/Equalize charge cycle phase is indicated by the Charge Complete (green) LED beginning to blink quickly. Not all charge profiles include a Balance/Equalize phase.
8. The charger automatically terminates the charge cycle when a battery reaches full charge, which is indicated by [1] the solid illumination of the Charge Complete (green) LED or [2] the Charge Complete (green) LED beginning to blink slowly indicating a post-charge phase. The required charge time is affected by numerous factors, including battery amp-hour capacity, depth of discharge, battery temperature, and battery age/usage.
9. Disconnect the charger AC power cord from the outlet before operating the vehicle/equipment.

10.3 Storage Mode Operation

1. Storage Mode is designed to keep your battery maintained during storage periods that last a few weeks to several months at a time.
2. Depending on the battery type, a storage charge can be a continuous float or a periodic charge mode.
3. Do NOT disconnect the charger from the battery or from the AC power while your machine is not being used. Disconnecting and reconnecting the charger from the batteries or AC power may start a charge cycle, but disconnection disrupts the storage mode so optimum battery maintenance is not achieved.
4. After several months of storage your batteries should be serviced and the charger reset by disconnecting the DC for Off-Board or the AC for On-Board applications (disconnect AC for a minimum of 10 minutes) before continuing another storage season..

11. LED INDICATORS

The charger includes three (3) LEDs to indicate charger status and fault information. The functionality of the LEDs is outlined below. If the charger is equipped with a remote LED assembly, this assembly also includes three (3) LEDs with identical functionality.

CHARGE STATUS (yellow)

Indicates charge cycle status. See Figure 11-1 for descriptions of the possible states.

CHARGE COMPLETE (green)

Indicates when a charge cycle completes successfully, when an extended Balance/Equalize charge cycle phase is active, or when a post-charge phase is active. See Figure 11-1 for descriptions of the possible states.

FAULT (red)

Indicates when a charger or battery fault has occurred. See the FAULTS section.

Charge Status (Yellow) LED	Charge Complete (Green) LED	Description
Slow Blink	Off	Bulk/Start charge cycle phase (constant power or constant current).
Fast Blink	Off	Absorption/Plateau charge cycle phase (constant voltage). Greater than 80% charged.
Solid On	Off	Finish charge cycle phase (constant current). Not all charge profiles include a Finish phase.
Off	Fast Blink	Balance/Equalize phase. An extended charge cycle is occurring because a trigger condition has been met (cycle count, etc). Not all charge profiles include a Balance/Equalize phase.
Off	Solid On	Charge cycle complete.
Off	Slow Blink	Charge cycle complete. Post Charge phase (constant voltage float, etc). Not all charge profiles include a Post Charge phase.

Figure 11-1: Charger LED States (Non-Fault)

12. FAULTS

(0) = Off

(1) = On Solid

N/A = Not applicable, LED state does not matter

	Fault (Red) LED	Charge Status (Yellow) LED	Charge Complete (Green) LED	Description
Charger	Slow Blink	1	1	DC DISCONNECT – DC disconnect detected via the third-pin, but DC (battery) voltage is still present at the charger output. (Third-pin DC disconnect sensing is an optional feature available with supported DC plug/receptacle systems to minimize charger output inhibit time when a DC disconnect occurs during charging.)
	Slow Blink	0	1	OVER TEMP – Maximum temperature was met. Charge cycle will restart when the temperature decreases.
	Slow Blink	1	0	LOW DC – DC (battery) voltage is too low to start charging (< 10V).
	Slow Blink	0	0	NO AC – AC power was lost during charging. Charge cycle will restart when AC power returns.
	Slow Blink	1	Slow Blink	HARDWARE FAULT – Contact Lester Electrical.
	Slow Blink	Slow Blink	0	HARDWARE FAULT – Contact Lester Electrical.
	Slow Blink	Slow Blink	1	HARDWARE FAULT – Contact Lester Electrical.
	Fast Blink	N/A	N/A	HARDWARE FAULT – Contact Lester Electrical. Unit is still able to charge.
Battery	1	0	0	PHASE – A fault condition (most commonly maximum time) was met during a particular charge cycle phase (start/bulk, plateau/absorption, finish, etc).
	1	0	Slow Blink	MAX VOLTAGE – Maximum voltage was met.
	1	0	1	MIN VOLTAGE – Minimum voltage was NOT met after a specified time from the start of the charge cycle.
	1	Slow Blink	0	MAX AMP-HOURS – Maximum amp-hours for the overall charge cycle was met.
	1	Slow Blink	Slow Blink	MAX TIME – Maximum time for the overall charge cycle was met.

Figure 12-1: Charger LED States (Faults)

Disconnecting the charger from the battery always clears a fault. If the charger was factory-configured for on-board use, removing AC power from the charger also clears a fault. If a fault cannot be cleared after taking appropriate corrective action, contact your dealer for troubleshooting and/or service.

13. TROUBLESHOOTING

The charger was fully tested and calibrated before leaving the factory. It was delivered ready to charge. If properly installed, the charger should require very little attention. If improper charger operation occurs, it will require repair by a qualified service technician.

 CAUTION: DO NOT OPERATE THE CHARGER IF IT IS DAMAGED OR APPEARS TO BE MALFUNCTIONING. PERSONAL INJURY OR DAMAGE TO THE CHARGER OR BATTERIES MAY RESULT. DO NOT DISASSEMBLE THE CHARGER. CONTACT YOUR DEALER. INCORRECT REASSEMBLY MAY RESULT IN RISK OF ELECTRIC SHOCK OR FIRE.

See the FAULTS section for information regarding the Fault LED.

1. If the charger does not turn on, check for one of the following conditions.
 - a. The charger AC power cord is not plugged into a live and/or appropriate AC outlet.
 - b. The battery connections are incorrect – battery not connected, reverse polarity, or short circuit.
 - c. The battery voltage is too high.
 - d. The battery voltage is too low (below 10 volts).
2. If the charger turns off before a battery is fully charged, and a fault condition is not indicated by the Fault LED, this indicates one of the following conditions.
 - a. The AC power was interrupted during the charge cycle.
 - b. The charger DC output connector was disconnected from the battery during the charge cycle.
 - c. The battery has been allowed to sulfate. Charge the battery at least once every three (3) days when the equipment is lightly used. Once sulfation is allowed to take place, it may be partially reduced by returning, temporarily, to daily charging.
3. A decrease in vehicle/equipment range where the battery loses power faster indicates one of the following conditions.
 - a. The electrolyte level in a wet lead-acid battery was allowed to drop below the top of the battery plates. If so, add distilled water to just cover the top of the plates immediately upon discovery, and then fill to the proper level with distilled water at the completion of the very next charge cycle.
 - b. Use of the vehicle/equipment before the battery has been fully charged and the charger automatically terminates the charge cycle. This shortens battery life and accelerates the onset of reduced daily range.
 - c. The normal wear-out pattern for the battery.
4. A charge cycle running longer than anticipated before terminating indicates one of the following conditions.
 - a. An overly-discharged battery.
 - b. The charger output may have been reduced due to low AC input voltage, high ambient temperature, or obstructions to cooling airflow.
 - c. The amp-hour capacity of the battery is greater than the charger can fully charge in the anticipated amount of time.

14. SPECIFICATIONS

AC Input

Voltage range, rated	100-230 Vac
Voltage range, operating	90-264 Vac (< 100 Vac: reduced power)
Frequency, rated	50-60 Hz
Frequency, operating	45-65 Hz
Phase	Single-phase
Current, maximum	27790, 27800, 28110, 28120, 27940, 27950: 8A 28000, 28230: 12A
Protection	Current limit, surge, transient, under voltage

DC Output

Voltage, nominal	27790, 27800, 28000:	48 Vdc
	28110, 28120, 28230:	36 Vdc
	27940, 27950:	24 Vdc
Voltage, maximum	27790, 27800, 28000:	72 Vdc
	28110, 28120, 28230:	54 Vdc
	27940, 27950:	36 Vdc
Voltage, minimum start-up	10 Vdc	
Power	28110, 28120:	640 W
	27790, 27800, 27940, 27950:	700 W
	28230:	950 W
	28000:	1050 W
Current, rated	27790, 27800:	13 A
	28110, 28120:	14.5 A
	28000:	19.5 A
	28230:	21 A
	27940, 27950:	25 A
Current, maximum	27790, 27800, 28110, 28120:	14.5 A
	28000, 28230:	21A
	27940, 27950:	25 A
Battery types	Wet/flooded, AGM, gel deep-cycle lead-acid; lithium-ion; custom. (See Section 3 for additional details.)	
Protection	Current limit, short circuit, reverse polarity, under voltage, over voltage, wrong battery voltage	

LEDs

Charge Complete (green),
Charge Status (yellow),
Fault (red)

Lockout Control

Optional. Pulls down to battery neg (-) when active. See Section 7 for options and additional details.

Battery Temp Sensor

Optional

Remote LEDs

Optional

Mechanical

Dimensions & mounting pattern	See Figures 2.2 and 2.3
Weight (approximate)	Case #1: 9 lbs (4.1 kg) Case #2: 12 lbs (5.5 kg)
Cooling	Natural convection (no fan)
AC connector	IEC 60320 C16 inlet with cord clamp
Mounting	Shelf, wall, bulkhead, threaded steel rod (with optional handle), hook (with optional handle). See Figure 2.1 for additional details.
Handle	Optional

Environmental

Enclosure rating	IP66, NEMA 4
Operating temperature	-25 degrees C to 60 degrees C (-13 degrees F to 140 degrees F). See datasheet for temperatures and mounting orientations where power reduction occurs.
Storage temperature	-40 degrees C to 85 degrees C (-40 degrees F to 185 degrees F)

NOTES



Represented By:

